



LABS, INC. 534 Main Street, Westbury, N.Y. 11590 (516) 334-5959

**IMF-600 IMPEDANCE
AND MULTIFUNCTION METER
INSTRUCTION MANUAL**

Copyright © 1982 IET labs, Inc.

IET-IM-IMF600-A12
MAY 1982

● PRECISION INSTRUMENTS FOR TEST AND MEASUREMENT ●



WARRANTY

We warrant that this product is free from defects in material and workmanship and, when properly used, will perform in accordance with applicable IET specifications. If within one year after original shipment it is found not to meet this standard, it will be repaired or, at the option of IET, replaced at no charge when returned to IET. Changes in this product not approved by IET or application of voltages or currents greater than those allowed by the specifications shall void this warranty. IET shall not be liable for any indirect, special, or consequential damages, even if notice has been given to the possibility of such damages.

THIS WARRANTY IS IN LIEU OF ALL OTHER WARRANTIES, EXPRESSED OR IMPLIED, INCLUDING, BUT NOT LIMITED TO, ANY IMPLIED WARRANTY OF MERCHANTABILITY OR FITNESS FOR A PARTICULAR PURPOSE.



WARNING

OBSERVE ALL SAFETY RULES WHEN MEASURING HIGH VOLTAGES OR LINE VOLTAGES.

#####

EXERCISE CAUTION WHEN APPLYING A HIGH BIAS VOLTAGE.

#####

DO NOT CONNECT THE IMF COMMON TERMINAL (ON REAR PANEL) TO EXTERNAL GROUND WHEN MEASURING A SIGNAL REFERENCED TO THAT EXTERNAL GROUND.

#####

DO NOT APPLY ANY TEST VOLTAGE OR CURRENT GREATER THAN SPECIFIED.

DO NOT TEST CAPACITORS WITH A CHARGE GREATER THAN SPECIFIED.

DISCHARGE CAPACITORS AFTER APPLYING A BIAS VOLTAGE.

#####

DANGEROUS VOLTAGES EXIST INSIDE THIS INSTRUMENT. MAINTENANCE INSTRUCTIONS WITHIN THIS OR ANY ASSOCIATED SERVICE MANUAL ARE FOR USE BY QUALIFIED SERVICE PERSONNEL ONLY. TO AVOID ELECTRICAL SHOCK, DO NOT ATTEMPT ANY SERVICING OTHER THAN THAT CONTAINED IN THE OPERATION INSTRUCTIONS UNLESS YOU ARE QUALIFIED TO DO SO.



TABLE OF CONTENTS (Continued)		
SECTION	TITLE	PAGE
4.2	Notes on Reliable Frequency Measurement	4-1
5.0	SYSTEM OUTPUTS	5-1
5.1	Analog Outputs	5-1
5.2	Digital Outputs (Optional)	5-1
6.0	CALIBRATION	6-1
6.1	Disassembly Procedure	6-1
6.2	Calibration Steps	6-1
	6.2.1 Power Supply Check	6-1
	6.2.2 DC Voltage Calibration	6-1
	6.2.3 AC Voltage Calibration	6-3
	6.2.4 1kHz Frequency Check	6-4
	6.2.5 Balance	6-4
	6.2.6 Basic Impedance Calibration	6-4
	6.2.7 Resistance Calibration	6-5
	6.2.8 Low Conductance Calibration	6-5
	6.2.9 Capacitance Calibration	6-5
	6.2.10 Low Inductance Calibration	6-6
	6.2.11 Dissipation Factor Calibration	6-6
	6.2.11.1 Dissipation Factor Balance	6-6
	6.2.11.2 Dissipation Factor Gain Setting	6-7

TABLE OF CONTENTS

SECTION	TITLE	PAGE
1.0	INTRODUCTION	1-1
1.1	Description	1-1
1.2	Principle of Operation	1-3
1.3	Kelvin (4-Terminal) Measurement	1-5
2.0	SPECIFICATIONS	2-1
2.1	General Specifications	2-1
2.2	Frequency Counter(Optional) Specifications	2-2
2.3	Options and Accessories	2-3
3.0	OPERATION	3-1
3.1	Basic Setup	3-1
3.2	General Procedure	3-1
3.3	Voltage Measurement	3-3
3.4	Current Measurement	3-3
3.5	AC True RMS Measurement	3-4
3.6	Resistance and Conductance Measurement	3-6
	3.6.1 1 kHz Resistance and Conductance Measurement Considerations	3-6
	3.6.2 Conductance Measurement	3-6
	3.6.3 High Resistance Measurement	3-6
	3.6.4 Low Resistance Measurement	3-8
3.7	Capacitance Measurement	3-8
	3.7.1 General Procedure	3-8
	3.7.2 Low Capacitance Measurement	3-10
	3.7.3 High Capacitance (>200 uF) Measurement	3-11
3.8	Inductance Measurement	3-11
	3.8.1 General Procedure	3-11
	3.8.2 High Inductance Measurement	3-13
	3.8.3 Low Inductance Measurement	3-13
3.9	Determination of the Dissipation Factor (D) of Capacitors	3-13
3.10	Determination of the Quality Factor (Q) of Inductors	3-14
3.11	Application of a DC Bias Voltage Across a Capacitor	3-15
3.12	Application of a DC Bias Current Through an Inductor	3-17
4.0	FREQUENCY COUNTER (OPTIONAL)	4-1
4.1	General Procedure	4-1

LIST OF ILLUSTRATIONS

FIGURE	TITLE	PAGE
1.1	IMF-600 Impedance and Multifunction Meter	1-2
1.2	Impedance Computation Scheme	1-4
3.1	Resistance Measurements of Resistor-Capacitor Combinations	3-7
3.2	Capacitance Models	3-9
3.3	Inductance Models	3-12
3.4	Applying a DC Bias Voltage Across a Capacitor	3-16
3.5	Applying a DC Bias Current through an Inductor	3-18
5.1	Output Strobe Timing	5-4
6.1	Adjustment and Test Point Locations	6-2

LIST OF TABLES

TABLE	TITLE	PAGE
3.1	Display Conditions and Causes	3-2
3.2	RMS and Average Responding Meter Conversions	3-5
5.1	Digital Output Connector Pin Assignments	5-3

1.0 INTRODUCTION

1.1 Description

The IET Labs IMF-600 Impedance and Multifunction Meter (Figure 1.1) is an automatic instrument for measurement of the following quantities:

CAPACITANCE	}	simultaneously
CONDUCTANCE		
DISSIPATION FACTOR (D)		

INDUCTANCE	}	simultaneously
RESISTANCE		
QUALITY FACTOR ($Q=1/D$)		

DC VOLTAGE
DC CURRENT
AC VOLTAGE (true RMS)
AC CURRENT (true RMS)

FREQUENCY (optional)

This versatile instrument can be used as a digital multimeter in addition to being a convenient "unknown" measuring device. Virtually any passive component may be categorized in terms of a simple or complex impedance.

All that is required to measure an unknown quantity, is to connect the 4-terminal Kelvin leads, to press the appropriate pushbutton and to select a range. The quantity and the units are automatically indicated with an unambiguous 3-1/2 digit display and clear back lighted annunciators.

The 4-terminal Kelvin leads permit the measurement of very small impedances such as the resistance of wires or connectors.

Capacitors and inductors may be selected by considering their lossy component (D or $1/Q$); this can be useful in discriminating between seemingly equivalent components. Capacitors or inductors may, in many cases, be measured in circuit without the necessity of removing them.

Analog outputs for all quantities are provided on the rear panel; a digital BCD output is available as an option. Either of these outputs may be used with a companion comparator unit for both impedance AND dissipation factor.





Figure 1.1 IMF-600 Impedance and Multifunction Meter



1.0 INTRODUCTION

1.1 Description

The IET Labs IMF-600 Impedance and Multifunction Meter (Figure 1.1) is an automatic instrument for measurement of the following quantities:

CAPACITANCE
CONDUCTANCE
DISSIPATION FACTOR (D) } simultaneously

INDUCTANCE
RESISTANCE
QUALITY FACTOR ($Q=1/D$) } simultaneously

DC VOLTAGE
DC CURRENT
AC VOLTAGE (true RMS)
AC CURRENT (true RMS)

FREQUENCY (optional)

This versatile instrument can be used as a digital multimeter in addition to being a convenient "unknown" measuring device. Virtually any passive component may be categorized in terms of a simple or complex impedance.

All that is required to measure an unknown quantity, is to connect the 4-terminal Kelvin leads, to press the appropriate pushbutton and to select a range. The quantity and the units are automatically indicated with an unambiguous 3-1/2 digit display and clear back lighted annunciators.

The 4-terminal Kelvin leads permit the measurement of very small impedances such as the resistance of wires or connectors.

Capacitors and inductors may be selected by considering their lossy component (D or $1/Q$); this can be useful in discriminating between seemingly equivalent components. Capacitors or inductors may, in many cases, be measured in circuit without the necessity of removing them.

Analog outputs for all quantities are provided on the rear panel; a digital BCD output is available as an option. Either of these outputs may be used with a companion comparator unit for both impedance AND dissipation factor.



Figure 1.1 IMF-600 Impedance and Multifunction Meter

1.2 Principle of Operation

The impedance Z_x of an unknown component X is defined as:

$$Z_x = V_x / I_x$$

where V_x is the complex voltage across the unknown and I_x is the current through the unknown. The IMF-600 implements this computation as shown conceptually in Figure 1.2. A sine wave generator drives current I_x through the unknown Z_x and standard resistor R_s in series with it. Two ac coupled differential amplifiers produce the voltages V_x and V_r across the unknown and the resistor respectively. The impedance Z_x may then be computed as follows:

$$Z_x = V_x / I_x$$

$$Z_x = R_s V_x / V_s$$

Except for resistance and conductance, Z_x is a complex ratio with real and imaginary components which must be computed.

In order not to introduce any errors from the computation of a ratio, a feedback control circuit is employed to maintain either V_x or V_s constant. For capacitance and conductance, V_x is maintained fixed, and the value of the unknown is determined as follows:

$$(C \text{ or } G) = a / Z_x = b V_s$$

where C and G are the capacitance or the conductance respectively, and a and b are constants of proportionality (different for C and G).

For inductance and resistance measurement, V_s is kept constant by the feedback control circuit, and the computation is performed as follows:

$$(L \text{ or } R) = c Z_x = d V_x$$

where L and R are the inductance or the resistance respectively, and c and d are constants of proportionality (different for L and R).

The voltage being measured, e.g. V_x , is broken down into the "in phase" (0°) and "quadrature" (90°) components with respect to the test signal. These are used to provide the real and imaginary portions of the complex impedance. A pure resistance, for example, will produce only an "in phase"

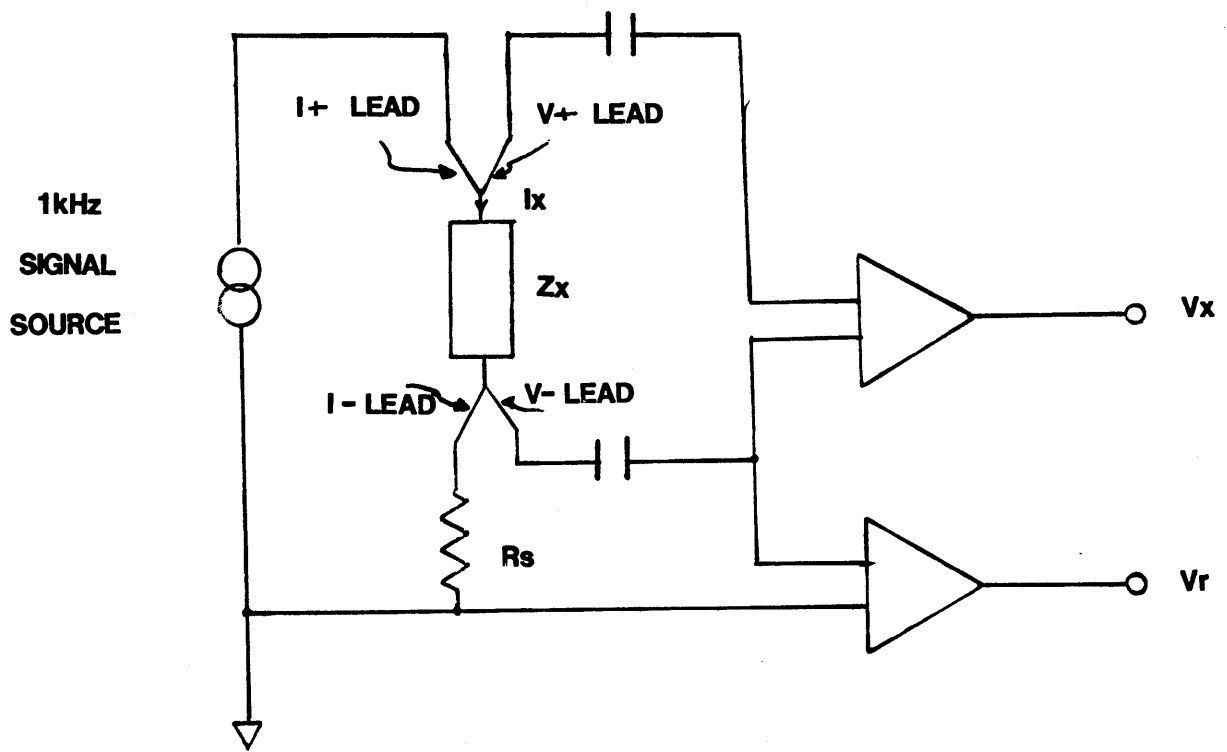

Figure 1.2 Impedance Computation Scheme

component, whereas an ideal capacitor will result in only a "quadrature" signal.

1.3 Kelvin (4-Terminal) Measurement

As may be seen in Figure 1.2, four physical conductors are actually brought out to connect to the component under test. Each two conductors are in electrical contact with each other as well as with one end of the device. They are, therefore, nominally equivalent to a single test lead. The difference becomes clear when the resistance of the test leads and of contacts are taken into consideration.

The test current is delivered to the device by leads I+ and I-. The lead pair V+ and V- are the voltage sensors which are brought directly to the component. If the voltages were sensed within the instrument, they would include the potentials developed across the current carrying leads due to their inherent resistance. Clearly, this can be very significant when measuring small impedances. Measuring the voltages right at the component eliminates this problem. The IMF-600 is therefore suitable for measuring the resistance of wire, connectors, or other "short circuits".



2.0 SPECIFICATIONS

2.1 General Specifications

	FULL SCALE RANGES	NO. OF RANGES	BASIC ACCURACY
CAPACITANCE	200.0pF to 200.0 μ F (20,000 μ F) ¹	7	0.25% \pm 1LSD \pm 1% of G reading
INDUCTANCE	200.0 μ H to 200.0H	7	0.25% \pm 1LSD \pm 1% of R reading
RESISTANCE	2.000 Ω to 2000.k Ω (1000M Ω) ²	7	0.25% \pm 1LSD \pm 0.5% of L reading
CONDUCTANCE	2.000 μ S to 2000.mS	7	0.25% \pm 1LSD \pm 0.5% of C reading
DISSIPATION (D or 1/Q)	2.000	na	1% \pm 2LSD for C or L >200 counts
DC VOLTAGE	200.0mV to 1000.V	5	0.1% \pm 1LSD
DC CURRENT	200.0 μ A to 2000.mA	5	0.2% \pm 1LSD
RMS VOLTAGE	2.000mV to 750.V	5	0.5% \pm 2LSD (Basic); 50Hz to 20kHz
RMS CURRENT	200.0 μ A to 2000.mA	5	0.5% \pm 2LSD (Basic); 50Hz to 20kHz
FREQUENCY (IMF-600F)	200.0Hz to 20.00MHz ³	6	0.1% \pm 1LSD

1. Extend by using the Inductance Function 2. Extend by using the Conductance Function

3. Resolution for all but the 200.0 Hz range may be extended to 4-1/2 digits by going to the next lower range.

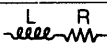
TEST FREQUENCY	1 kHz for impedance functions.
IMPEDANCE MODELS	C  G or 
TEST VOLTAGE	C&G: Ranges (1-6) 1.4 VRMS; Range (7) 0.14 VRMS.
TEST CURRENT	L&R: Range (1) 110 mA; Ranges (2 & 3) 11 mA; Range (4) 1.1mA; Range (5) 110 μ A; Range (6) 11 μ A; Range (7) 1.1 μ A.
BIAS	Up to 100 VDC may be applied in series with unknown impedance.
INPUT IMPEDANCE	10M Ω on voltage functions.
BURDEN VOLTAGE	0.3V maximum on all ranges, except 1.4V maximum on 2A range.
READING RATE	4 measurements per second.
DISPLAY	3 $\frac{1}{2}$ digit LED, with corresponding annunciator. All decimal points on indicate overrange or illegal condition.
OUTPUTS	ANALOG: L,R,C,G,V, or I plus D (or 1/Q) if applicable, scaled at 1V/1000 counts. DIGITAL: BCD output representing signed 3 $\frac{1}{2}$ digit meter reading (Optional).
TEST TERMINALS	4-terminal shielded Kelvin test leads.
OPERATING CONTROLS	Push button ON-OFF switch, rotary range select switch, and push button function select switches.
INPUT PROTECTION	VOLTAGE: 1000 V peak. COMMON MODE VOLTAGE (LO term to GND):500 V peak. CURRENT: 2A fuse protected. ALL OTHERS: 220 VRMS.
POWER REQUIREMENTS	105-125 V or 210-250 V; 50-60Hz; 5 W.
PHYSICAL	DIMENSIONS: 8.5"Wx9.25"Dx 4.44"H (216mm x 235mm x 113mm). WEIGHT: 6 lbs (2.7kg).
ACCESSORIES SUPPLIED	4-terminal shielded Kelvin test leads and instruction manual; unit comes with carrying handle which serves as a tilt stand.

TEST CONDITIONS: Performance specifications apply

- 1) after correction for test lead zero reading
- 2) after 10 minute warmup
- 3) between 15-35 $^{\circ}$ C

2.2 Frequency Counter (Optional) Specifications

Display: Overrange will be indicated when the frequency option is not present.

Range: 100.0 Hz to 20.00 MHz in 6 ranges,
30.0 Hz to 20.00 MHz typical

Resolution: 3-1/2 digits, may be extended to one additional least significant digit by downranging. This does not apply to Range 1 (200.0 Hz).

Gate Time: 10 seconds for 200.0 Hz range
1 second for 2.000 kHz range
0.1 second for 20.00 kHz range
10 ms for 200.0 kHz range
1 ms for 2.000 MHz range
0.1 ms for 20.00 MHz range

Sampling Period: 20 seconds for 200.0 Hz range
2 seconds for 2.000 kHz range
0.25 seconds for all other ranges

Impedance: >1 Megohm, diode protected

Coupling: AC

Sine Wave Sensitivity: 3 VRMS at 30 Hz
1 VRMS at 100 Hz
0.3 VRMS for 1 kHz-20 MHz

Maximum Input: 100 V peak 30 Hz-1 kHz
75 V peak 1 kHz-10 MHz
50 V peak 10 MHz-20 MHz

Time Base: 1 MHz crystal oscillator

2.3 Options and Accessories

- 1) -F Option for Frequency Counter
- 2) -D0 Option for signed 3-1/2 digit BCD output
- 3) LC-602 Dual Channel Analog Limits Comparator for simultaneous (C and D) or (L and D)
- 4) CLC-502 Single Channel Digital Limits Comparator. May be used for impedance OR dissipation or both quantities sequentially; Two comparators may be cascaded for simultaneous (C and D) or (L and D) testing. (Requires D0 option).



3.0 OPERATION

3.1 Basic Setup

Connect the IMF-600 to a grounded power source. Operation at either 110 or 220 VAC is possible by selecting internal straps. The proper operating line voltage is indicated underneath the unit along with an abbreviated operating guide.

Press the POWER switch which is a push-on push-release button; the displays will light. To adjust the tilt handle, pull outward on its pivots and set the handle to provide a convenient viewing angle.

3.2 General Procedure

Operation of the IMF-600 is straightforward:

- 1) Select the desired function with the front panel pushbutton. For voltage or current, select the appropriate position of the "DC/AC true RMS" button.
- 2) Connect the Kelvin terminals to the unknown component or source. The polarity of the leads has no significance except for dc measurements or the application of a bias voltage.
- 3) Turn the RANGE knob to obtain the highest "in range" reading, i.e. a number between 200-1999 counts. Overrange is indicated by all decimal points being lighted.
- 4) To obtain the dissipation factor for a capacitive or inductive component, press the "D" pushbutton in addition to the "C" or "L" button. The "D" button will have no effect in any of the other functions.

The correct measurement is displayed within one second and repetitive measurements are made at the rate of four per second; the decimal point and the unit of measure will be very clearly shown. If all decimal points are on, advance the range until a proper reading is obtained.

Table 3.1 shows the various display conditions which may occur along with their possible causes.

Table 3.1. Display Conditions and Causes

CONDITION	CAUSE
1. All decimal points are on	-Overrange; advance range knob; if ranges are exhausted on R, use G; if ranges are exhausted on C, use L (see sections 3.6.3 and 3.7.3). -F (Frequency) button is pressed in a unit not having that option
2. No decimal points are on	-None of the function buttons are depressed.
3. Negative impedance reading	-A capacitive component (or one effectively capacitive at 1kHz) is being measured with the "L" function. -An inductive component (or one effectively inductive at 1kHz) is being measured with the "C" function. -A nonlinear component such as a diode is being measured; such a component may require a bias voltage.

3.3 Voltage Measurement

For voltage measurement, the IMF-600 may be used like any digital multimeter. The "V" pushbutton should be depressed, and the "DC/AC" pushbutton should be out or in as desired for dc or ac true RMS measurement respectively. The red lead is the positive terminal, and the black lead is the common or negative terminal.

The shielded leads of the IMF-600 will provide some noise rejection when measuring a voltage across a high impedance.

The voltage function has the five conventional digital multimeter ranges of 200.0 mV, 2.000 V, 200.0V and 1000.V (750.V for AC) which correspond to Range knob settings of 1-5 respectively. Ranges 6 and 7 are repeats of Range 5, i.e. the 1000. V range.

WARNING

=====

OBSERVE ALL SAFETY RULES WHEN MEASURING HIGH VOLTAGES.

BE CAREFUL NOT TO TOUCH THE PROBE TIPS WITH YOUR FINGERS OR ALLOW THE PROBE TIPS TO TOUCH EACH OTHER.

DO NOT CONNECT THE COMMON TERMINAL ON THE REAR PANEL TO EARTH OR OTHER EXTERNAL GROUND WHEN MEASURING A VOLTAGE REFERENCED TO THAT GROUND SUCH AS A LINE VOLTAGE.

THE VOLTAGE ON THE BLACK LEAD APPEARS ON THE COMMON TERMINAL ON THE REAR PANEL.

DO NOT EXCEED THE MAXIMUM LIMITS FOR SAFE OPERATION OF THE INSTRUMENT:

MAXIMUM INPUT VOLTAGE: 1000 VOLTS PEAK

MAXIMUM COMMON MODE VOLTAGE: 500 VOLTS PEAK

=====

3.4 Current Measurement

For current measurement, the IMF-600 may be used like any conventional digital multimeter. The "I" pushbutton should be depressed, and the "DC/AC" pushbutton should be out or in as desired for dc or true RMS ac measurement respectively. The red lead is the positive terminal and the black lead is the common or negative terminal.

Due to the multifunctional nature of this instrument, it is necessary, for current measurement ONLY, that the current

carrying leads of the red and black Kelvin terminals be in electrical contact with the current source. For the sake of convenience, it is simpler, in practice to just be certain that BOTH ends of each Kelvin terminal are in contact with the current source.

The current function has the five conventional digital multimeter ranges of 200.0 uA, 2.000 mA, 20.00 mA, 200.0 mA, and 2000. mA which correspond to Range knob settings of 1-5 respectively. Ranges 6 and 7 are repeats of Range 5, i.e. the 2000. mA range.

The current function is protected with a 2 ampere fuse as well as with a diode circuit which prevents the voltage across the current measurement resistors from exceeding about 0.3 volts.

WARNING

=====
INSTRUMENT DAMAGE AND OPERATOR INJURY MAY RESULT IF THE FUSE BLOWS WHILE CURRENT IS BEING MEASURED IN A CIRCUIT WHICH EXHIBITS A OPEN CIRCUIT VOLTAGE GREATER THAN 500 VOLTS.
=====

3.5 AC True RMS Measurement

The IMF-600 measures the true RMS (root mean square) value of a signal which is defined as:

$$X_{rms} = \sqrt{\overline{X^2}}$$

where X is the mean or time average value of the signal X(t). The RMS value is therefore indicative of the power contained in a signal. In particular, the RMS value of an ac current or voltage is defined as being numerically equal to the dc current or voltage that produces the same heating effect in a given resistance that the ac current or voltage produces.

The older methods of ac measurement are usually signal averaging techniques, i.e. they provide the value $\overline{|X|}$, the average or dc value of the rectified signal. The two types of meters are usually calibrated to correspond only for a pure sine wave.

The RMS feature allows accurate measurement of common waveforms like distorted or mixed frequency sine waves, sawtooths, noise, pulse trains (with a duty cycle of at least 10%), etc. Voltage readings from ordinary average responding ac meters can be incorrect or misleading. Table 3.2 gives the

Table 3.2. RMS and Average Responding Meter Conversions

WAVEFORM	CALIBRATED AVERAGE RESPONDING METER	RMS METER
Sine	1.000	1.000
Square	1.110	1.000
Triangle	0.960	1.000
Full wave rectified sine	0.421	0.435
Pulse (D=fractional duty cycle)	2.22 D-D	2 D-D

conversion information for a number of common waveforms.

To measure a signal containing both ac and dc components, first measure the RMS value of the ac component using the ac function of the meter. Then measure the dc component using the dc function of the instrument. The relationship between the total RMS value of the waveform and the ac and dc components is:

$$\text{RMS}_{\text{total}} = \sqrt{(\text{ac comp RMS})^2 + (\text{dc comp})^2}$$

3.6 Resistance and Conductance Measurement

3.6.1 1 kHz Resistance and Conductance Measurement Considerations

In most cases, measurement of resistance or conductance (1/resistance) with the IMF-600 is equivalent to the measurement with an ordinary ohmmeter, and the resulting reading will be the same. Note, however, that the IMF-600 measures resistance at 1kHz, whereas an ohmmeter determines resistance at dc. For virtually all resistors, the result is identical, but care has to be taken when measuring complex components such as high value wire-wound resistors or multiple components such as a resistor-capacitor combination as shown in Figure 3.1.

3.6.2 Conductance Measurement

Conductance can be considered as either a new type of measurement or another way to measure resistance, and in particular high resistance (Section 3.6.3). Conductance measurements are made by using the "G" function. The display is in conductance units, siemens (formerly known as mhos), where

$$G(\text{in siemens}) = 1/R(\text{in ohms}).$$

As a conductance meter, the IMF-600 can directly measure inverse-function components. For example, the resistance of a photodiode decreases as the available light increases; conductance and light level, therefore, increase or decrease together allowing easier, less error prone, testing. The same is true for a number of other variable resistance transducers. It is also sometimes easier, in circuit computations, to multiply by conductance than to divide by resistance.

3.6.3 High Resistance Measurement

In the resistance function, maximum measurement capability is 2 megohms. For resistances from 1999 kilohms to 1000 megohms, use Range 1 (2.000 uS) of the G (conductance) function where $G=1/R$. Except for high voltage stress testing, this range

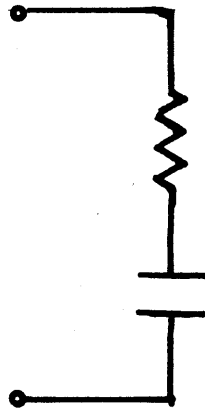

Ohmmeter reading: open circuit.

IMF-600 reading: finite.

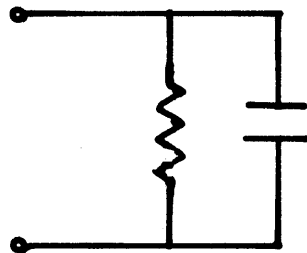

Ohmmeter reading: correct.

IMF-600 reading: correct, as long as "C" reading is not overrange. Range may be advanced in such a case. "G" and not "R" should be used for best accuracy.

Figure 3.1 Resistance Measurements of Resistor-Capacitor Combinations



can replace a megger for a number of applications. It can be used to check high value resistors and non-capacitive low leakage components.

High resistors should be guarded or shielded, if possible, by connecting the shield to the COMMON terminal on the rear panel of the meter.

3.6.4 Low Resistance Measurement

The IMF-600 is capable of measuring low resistance with a resolution of .001 ohm. The resistance of wires, connectors, or contacts can therefore be determined. The four-terminal Kelvin leads allow accurate low impedance measurement by eliminating contact resistance. This is accomplished by having the test current applied through the unknown by one pair of leads and measuring the voltage across it with the second pair. See Section 1.3.

Certain care does have to be taken in making low impedance measurements; the Kelvin leads should be clean and should grip firmly and consistently.

3.7 Capacitance Measurement

3.7.1 General Procedure

Measurement of capacitance is straightforward; simply press the "C" pushbutton and select the range providing the maximum resolution. Capacitance may be resolved to 0.1 pF, and values as high as 20,000 uF may be measured.

The capacitance model assumed by the IMF-600 is the parallel capacitor conductor (or resistor) combination as shown in Figure 3.2a, where C_p and G_p are the parallel equivalent capacitance and conductance respectively. For an ideal capacitor, conductance G_p is zero (infinite resistance). For a real capacitor, G_p represents the leakage or the various other loss elements. Most non-electrolytic capacitors are virtually ideal. For an in-circuit capacitor, G_p represents the conductance of the circuit across the unknown capacitor.

The IMF-600 will measure both C_p and G_p simultaneously and will display one or the other as buttons "C" or "G" are pressed. The dissipation factor

$$D = G_p / 2\pi f C_p$$

where f is the frequency (1000 in this case) is provided

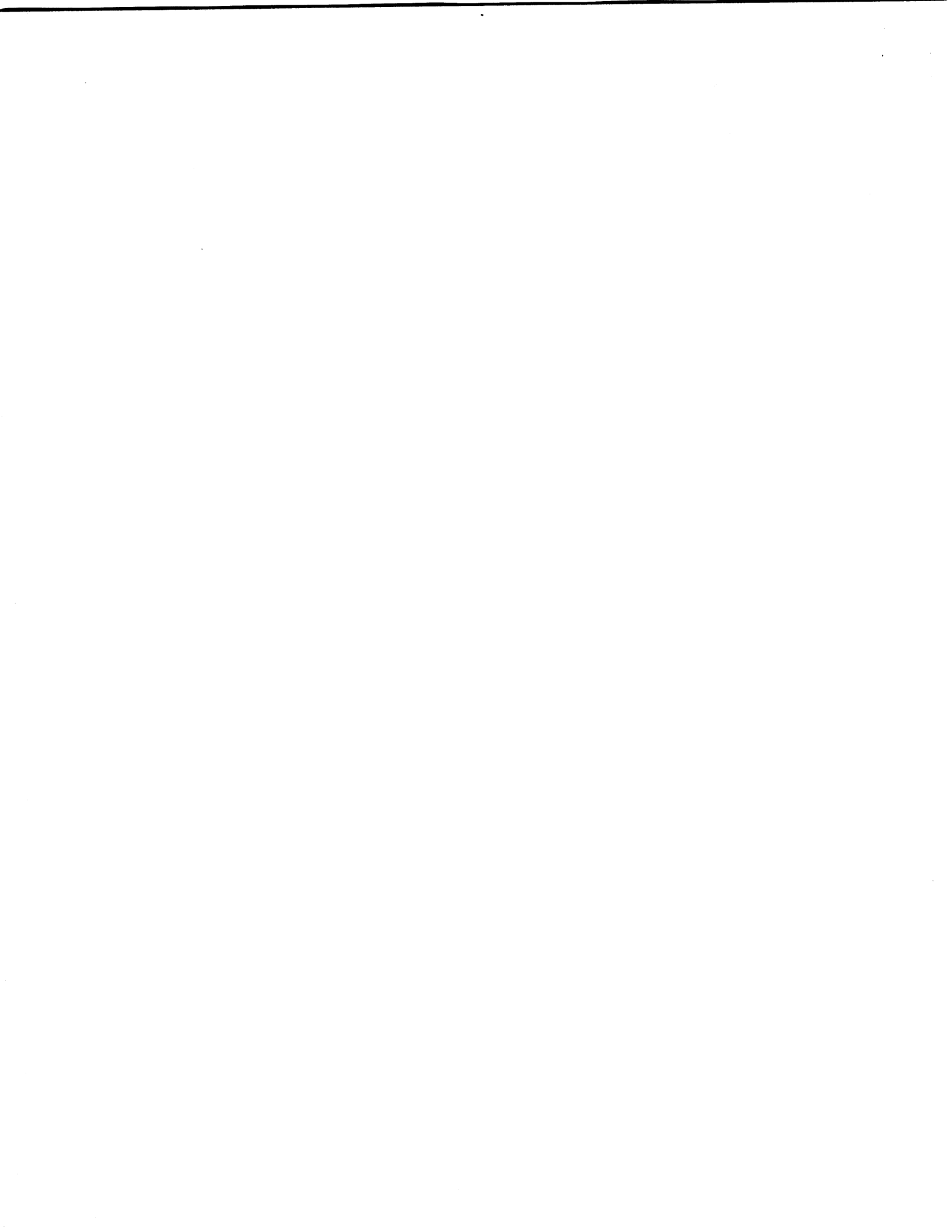

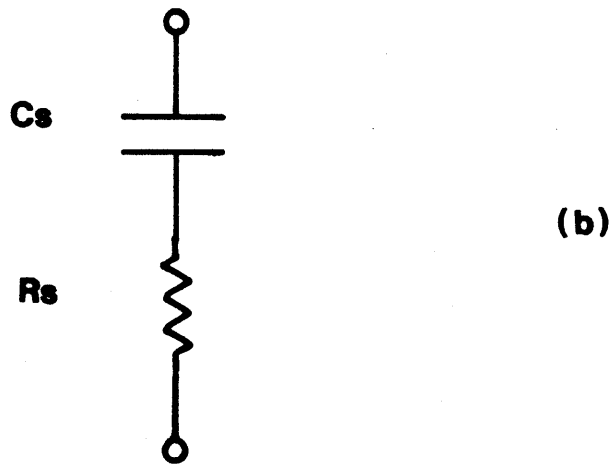
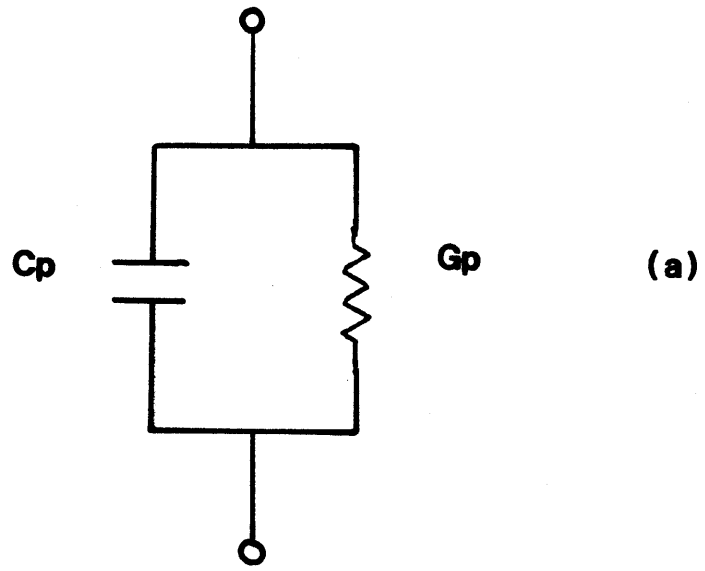

Figure 3.2 Capacitance Models

simultaneously whenever the "D" button is pressed. It is also continuously available on the rear panel analog output terminal. The range chosen should be for best capacitance, not conductance, resolution.

In-circuit capacitance may be measured as long as the conductance does not overwhelm the capacitance, i.e. as long as the conductance counts displayed are not much greater than the capacitance counts.

An alternative capacitor model is the series type shown in Figure 3.2b where C_s and R_s are the series equivalent capacitance and resistance respectively. The relationship between the two models is:

$$C_s = (1 + D^2) C_p.$$

$$R_s = D^2 / (1 + D^2) G_p$$

3.7.2 Low Capacitance Measurement

When measuring small capacitors, particularly on the lowest capacitance range (200 pF), two potential problems should be carefully avoided.

First, due to their high impedance, small capacitors should be shielded or guarded to the COMMON terminal on the rear panel. A metal case or a piece of foil connected to that terminal may be used.

Second, cable or stray capacitance can affect the measurement. Always maintain the physical orientation and position of the test leads during a test, since the capacitance reading may change by as much as a few picofarads as the lead separation or relative orientation is changed. Note that although the Kelvin leads are shielded, the tips are not and do present a capacitance between them. This residual capacitance must be kept constant, and may be either arithmetically subtracted from the reading or may be zeroed out by the ZERO C1 (or C2 for the second capacitance range) trimming potentiometer accessible from the rear panel.

All four conductors of the Kelvin leads are not required for low capacitance (or other high impedances), since the currents employed are small. The leads may therefore be lengthened with a pair of single conductors, as long as they are shielded, or the capacitance they contribute is taken into consideration.

3.7.3 High Capacitance (>200 uF) Measurement

The IMF-600 is a versatile instrument that allows measurement beyond the C7 range limit of 200 uF. High capacitors may be measured on the inductance function using the following conversion:

$$Cs = -1 / (2\pi f)^2 Ls = -2.533 \times 10^{-8} / Ls$$

where f=frequency in hertz (1000 in this case), Ls=series inductance in henries, and Cs=series capacitance in farads. Note that meter will display a negative reading. As an example, a 330 uF capacitor will read 76.7 uH. Note, however, that this is the series, not the parallel, equivalent capacitance.

3.8 Inductance Measurement

3.8.1 General Procedure

Measurement of inductance is straightforward; simply press the "L" pushbutton and select the range providing the maximum resolution. Inductance may be resolved to 0.1 uH, and values as high as 200 H may be measured.

The inductance model assumed by the IMF-600 logic is the series inductor-resistor combination shown in Figure 3.3a where Ls and Rs are the series equivalent inductance and resistance. For a real inductor, Rs represents the resistance of the conductor as well as the various other loss elements. Unlike capacitors which are often virtually ideal, inductors will have considerable finite resistance.

The IMF-600 will measure both Ls and Rs simultaneously and will display one or the other as buttons "L" or "R" are pressed. The quality factor Q is available as the reciprocal of the dissipation factor D, i.e. Q=1/D. They are defined as follows:

$$1/Q = D = 2\pi f Ls / Rs$$

where f=frequency in hertz (1000 in this case). The value for D is provided whenever the "D" pushbutton is pressed. It is also continuously available on the rear panel analog output.

The range chosen should be for best inductance, not resistance, resolution. Because a series inductance model is employed, in-circuit inductors may be measured only as long as the impedance across them is high.

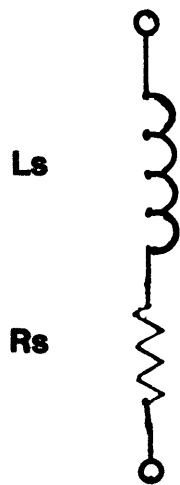

(a)

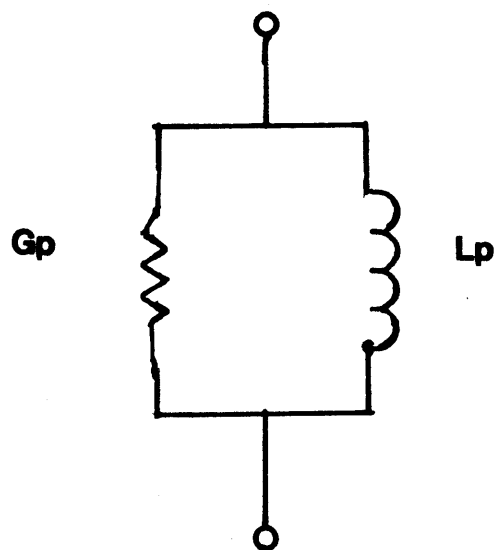

(b)

Figure 3.3 Inductance Models

An alternative inductance model is the parallel type shown in Figure 3.3b where L_p and R_p are the parallel equivalent inductance and resistance respectively. The relationship between the two models is:

$$L_p = (1 + D^2) L_s$$
$$G_p = 1 / (1 + Q^2) R_s$$

3.8.2 High Inductance Measurement

As in the case of low capacitance or high resistance, ac pickup should be avoided. The leads should be as short and direct as possible. The inductor under test may be shielded to the COMMON terminal on the rear panel, and the hands should be kept away. Stray capacitance will be minimized by following these steps. Additionally, care should be taken to avoid any external magnetic fields.

3.8.3 Low Inductance Measurement

Leads of the inductance under test may contribute some impedance on sensitive ranges. Closely spaced twisted leads will minimize inductance and pickup. The inductance of the Kelvin leads may be determined by shorting them together and either arithmetically subtracting the residual reading or eliminating it. This may be done with the ZERO L1 and L2 potentiometers accessible from the rear panel for inductance Ranges 1 and 2 respectively.

3.9 Determination of the Dissipation Factor (D) of Capacitors

The dissipation factor D of a capacitor is defined as

$$D = G_p / 2\pi f C_p$$

where C_p = the series equivalent capacitance, G_p = the series equivalent conductance, and f = frequency in hertz (1000 in this case). Clearly, D is zero for an ideal capacitor and high for a poor one.

D values up to 1.999 may be displayed by pressing the "D" pushbutton while the "C" pushbutton is depressed. The "D" pushbutton is a momentary switch. The lighted "D" annunciator is displayed along with the capacitance unit. The analog dissipation value is continuously available on the rear panel analog output terminal, with a scaling of 1 volt/1000 counts. It is not limited, however, to 1.999 volts but will actually go up

to over 4 volts, corresponding to a D of >4.

D values greater than 1.999 may be directly computed from the above relationship, or more simply by:

$$D=1.592 \text{ Gcount/Ccount}$$

where Gcount and Ccount are the displayed G and C counts on the same range, without decimal points. The range providing the maximum capacitance, not conductance, resolution must be used.

The "D" pushbutton has no effect except whenever the "C" or "L" pushbuttons are selected.

3.10 Determination of the Quality Factor (Q) of Inductors

The quality factor (Q) of an inductor is defined as:

$$Q=2\pi fL_s/R_s$$

where f=frequency in hertz (1000 in this case), L_s = series equivalent inductance, and R_s =series equivalent resistance. Clearly, Q is infinite for an ideal inductor and low for a poor one.

The IMF-600 computes the dissipation factor $D=1/Q$, which may be displayed by pressing the "D" pushbutton while the "L" pushbutton is depressed. The "D" pushbutton is a momentary switch. Q may then be computed as the reciprocal of D; this may be done so long as $Q>0.5$ (or $D<2$). For $Q<0.5$, the value may be directly computed from the above relationship, or more simply by:

$$Q=L\text{count}/1.592 \text{ Rcount}$$

where Lcount and Rcount are the displayed L and R counts on the same range without decimal points. Whenever possible, the range providing the maximum inductance, not resistance resolution must be used.

When the "D" pushbutton is pressed, the lighted "D" annunciator is displayed along with the inductance unit. The analog dissipation value is continuously available on the rear panel analog output terminal, with a scaling of 1 volt/1000 counts. It is not limited, however, to 1.999 volts but will actually go up over 4 volts, corresponding to D of 4 or a Q of <0.25.

The "D" pushbutton has no effect except whenever the "C" or "L" pushbuttons are selected.

3.11 Application of a DC Bias Voltage Across a Capacitor

Although ideal capacitors have a constant capacitance independent of the voltage across them, many electrolytic ones and other capacitive devices do not. The IMF-600 allows for the application of a dc voltage of up to 100 volts across the capacitor under test.

For safety of the operator, it is recommended that external bias be limited to a maximum of 30 V. If necessary, with proper precautions to safeguard from the danger of electric shock, higher voltages may be used.

In order to apply a bias voltage, connect an external dc voltage source as shown in Figure 3.4a. If the capacitance is high and contact resistance is significant, follow Figure 3.4b. Separate the red V+ and I+ leads and connect the V+ lead as directly to the capacitor as possible and apply the bias voltage between the I+ terminal and the capacitor as shown.

Shield or ground the capacitor if called for, as long as the shield is insulated from the two main terminals of the capacitor.

In order for the external supply to be able to provide the required bias without introducing measurement error, it must meet these requirements:

1. Supply the required dc bias voltage.
2. Provide the charging current.
3. Serve as source and sink for the measuring ac current which equals $2000\sqrt{CV_{test}}$, where $V_{test}=1.4$ VRMS for Ranges 1-6, and 0.14 VRMS for Range 7.
4. Appear as a low impedance, at 1 kHz, in comparison to the capacitor under test.

In order to make a power supply or battery suitable for this purpose, connect, across it, a bleeder resistor to act as a current sink, and a large capacitance (many times larger than the full scale value being used) to reduce its apparent impedance.

Note that that the the applied bias voltage does not completely develop across the capacitance under test. A small portion is taken up by the internal coupling capacitors. If the

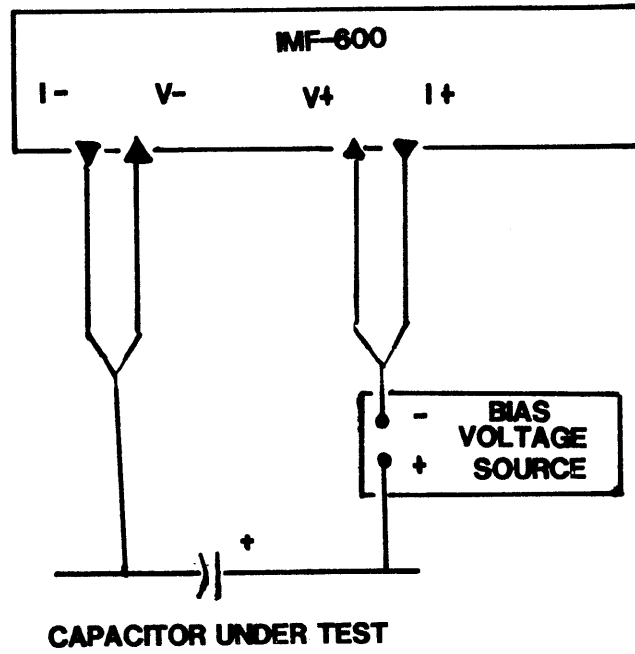

(a)

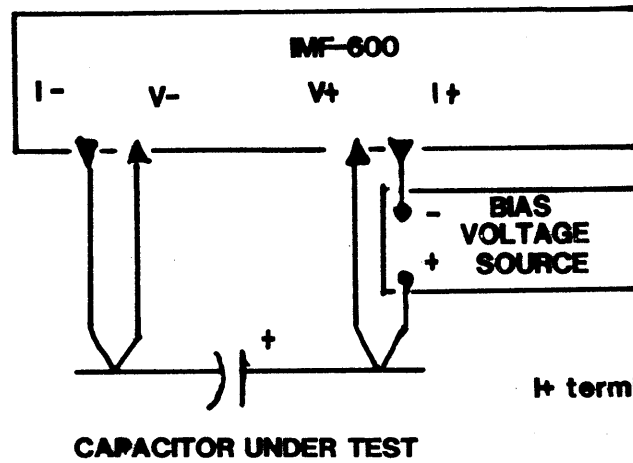

(b)

⊞ terminal is inner red lead

Figure 3.4 Applying a DC Bias Voltage Across a Capacitor

bias voltage must be precisely known, it should be measured across the capacitor, but not during the actual measurement.

WARNING

=====

TO MINIMIZE THE DANGER OF ELECTRIC SHOCK, LIMIT BIAS TO 30 V. BIAS VOLTAGE IS PRESENT AT KELVIN LEADS AND ON THE CAPACITOR UNDER TEST.

WHEN HIGH BIAS VOLTAGES ARE USED, DO NOT LEAVE THE INSTRUMENT UNATTENDED.

CAPACITORS REMAIN CHARGED AFTER TEST. DISCHARGE CAREFULLY.

=====

3.12 Application of a DC Bias Current Through an Inductor

Although ideal inductors have a constant inductance independent of the current through them, many real ones, especially those with saturating cores, do not. The IMF-600 permits the application of a dc current through the inductor under test.

To apply such a current, connect an external dc current source as shown in Figure 3.5. It is necessary that the impedance of the current source, or the entire circuit in parallel with the inductor under test, be sufficiently high in comparison with the impedance of the inductor at 1kHz. Or, the impedance of the current circuit may be determined separately, with the IMF-600, and its effect on the inductance measurement computed.

Shield or ground the inductor if called for, as long as the shield is insulated from the two main terminals of the inductor.



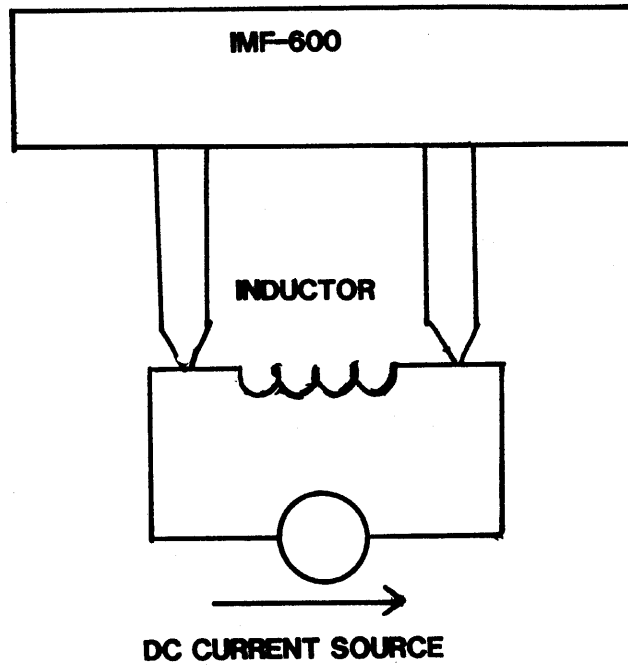

Figure 3.5 Applying a DC Bias Current through an Inductor



4.0 FREQUENCY COUNTER (OPTIONAL)

4.1 General Procedure

The use of the IMF-600 for frequency measurements is straightforward. All that is required is to press the "F" pushbutton and to select the range providing the maximum resolution. Units not having the frequency counter option will display overrange, i.e. all decimal points will be on.

The frequency function has 6 ranges of 200.0 Hz, 2.000 kHz, 20.00 kHz, 200.0 kHz, 2.000 MHz, and 20.00 MHz which correspond to Range knob settings of 1-6 respectively. Range 7 is a repeat of Range 6, i.e. the 20.00 MHz range.

The nominal display will provide a 3-1/2 digit reading, but the internal frequency computation is made to 4-1/2 digits. This additional significant figure may be viewed by downranging and reading the two least significant digits to replace the single least significant digit of the original range. If, for example a reading of 18.53 kHz is seen on Range 3, going to Range 2 may give the reading X.5.2.7. where X indicates a meaningless digit and the decimal points show overrange. The resultant 4-1/2 digit reading, in this example, is 18.527 khz. This is also a more reliable measure since it is obtained over a ten times longer gating period. Clearly this procedure cannot be applied for Range 1 (200.0 Hz).

4.2 Notes on Reliable Frequency Measurement

There are a number of important considerations in taking reliable readings. These are based on knowing the signal source characteristics, the counter input characteristics, and the coupling between the two.

The IMF-600 has a high sensitivity, and if the signal source is basically noisy, the count may be quite meaningless. It is important that the signal to noise ratio be as high as possible; a ratio of one hundred to one may be needed to obtain stable measurements. The stability of the input signal source, or lack of it, may also cause noise or variation in the reading. In some cases, especially for relatively low frequencies, a small bypass capacitor may be used to clean up the input signal.

It is sometimes helpful under noisy or high frequency conditions to use a separate grounding lead from the black Kelvin test lead to the COMMON terminal on the rear panel.

It is important to be aware that the the test leads will appear as approximately 100 pF of capacitance. Any additional external cables will also contribute to such a loading. Where practical these should be kept as short as possible. Nevertheless, the cable may load down or detune high impedance signal sources.

If high level high frequency signals cause unstable frequency readings or display segment flicker, the input should be attenuated if possible.

5.0 SYSTEM OUTPUTS

5.1 Analog Outputs

The impedance quantity being displayed will appear as an analog voltage, scaled at 1 volt/1000 counts, at the rear panel connector. The dissipation factor D is also brought out similarly scaled. These voltages may be observed with respect to the center COMMON terminal.

In the IMF-600, processing occurs in analog form, and the quantity being determined is computed as an analog voltage which is fed to a 2 volt, 2000 count, analog to digital converter. Although this converter cannot handle signals greater than 2 volts, such "overrange" signals are still brought out to the back panel, and may be correct even while the display indicates overrange. Such outputs (>2 volts) must be used WITH CAUTION, because the upper legal limit is not the the same for all ranges or functions, but they may be useful in many cases.

The analog outputs may be used with a Limits Comparator such as the IET Labs Model LC-602 for upper and lower limits selection and for "D" lower than a preset maximum. This combination becomes a powerful GO/NO GO testing, quality control, or selection system.

5.2 Digital Outputs (Optional)

Units with a "DO" option provide a connector on the rear panel with a signed BCD representation of the displayed value on any selected function. This output is the BCD equivalent of the analog to digital converter output. When the "D" button is pressed, the dissipation becomes the digital value being output. Unlike the analog signals, only one, not two quantities, is output at any one time.

The digital outputs may be used with the IET Labs Model CLC-502 Digital Limits Comparator for upper and lower limits selection. These comparators may be cascaded for dissipation value testing or for bin sorting.

The digital output pin assignments are given below in Table 5.1. The digital output connector is a 26 pin header on the rear panel. It may be accessed with a "3M Company Model 3399", "GTE Sylvania Inc. Model 6BAXx-26-lxx-xx", "T&B/Ansley Corp. Model 609-2600M", or equivalent socket connector. The rear panel connector pin numbering, as the connector is viewed straight on, is also shown in Table 5.1.

The output level is 5 volt positive true logic, capable of driving CMOS or TTL loads. A strobe, an overrange indicator, and +5 volts are also brought out. The strobe timing waveform is shown in Figure 5.1.

Table 5.1 Digital Output Connector Pin Assignments

PIN NO.	FUNCTION
1	+5 V
2	Ground
3	10 bit
4	20 bit
5	Sign bit, true (high) for negative and false (low) for positive
6	No connection
7	No connection
8	No connection
9	No connection
10	No connection
11	No connection
12	No connection
13	No connection
14	Overrange bit, true (high) during overrange condition
15	Strobe pulse; see Figure 5.1.
16	40 bit
17	4 bit
18	1 bit
19	2 bit
20	200 bit
21	400 bit
22	800 bit
23	80 bit
24	1000 bit
25	8 bit
26	100 bit

Connector Pin Numbering

13	12	11	10	9	8	7	6	5	4	3	2	1
26	25	24	23	22	21	20	19	18	17	16	15	14

(Viewed Straight on)

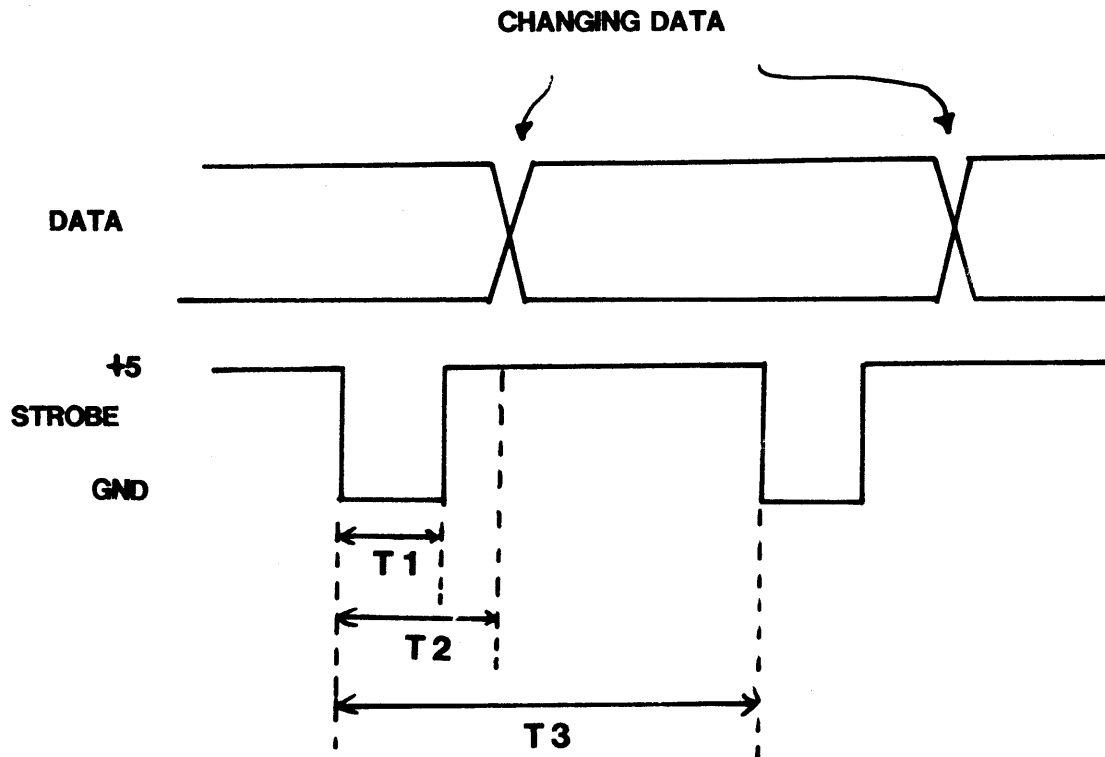

	Frequency Counter	All Other Functions
T1	30 us	90 ms
T2	10 us	110 ms
T3	See "Sampling Period", Section 2.2	250 ms

Figure 5.1 Output Strobe Timing

6.0 CALIBRATION

The IMF-600 should be calibrated every six months or if incorrect readings are obtained. Since this instrument measures so many quantities, the calibration procedure is lengthy and requires a number of calibration standards or meters. The procedure is arranged, however, so as to allow bypassing items for which accuracy is not of interest.

Calibration may also be provided by the IET Labs for a nominal charge.

6.1 Disassembly Procedure

Remove the four screws on the bottom of the unit. Carefully remove the top cover.

WARNING

=====
ALTHOUGH NO HIGH VOLTAGES EXIST ON THE UPPER CIRCUIT BOARD,
DANGEROUS VOLTAGES DO EXIST INSIDE THE INSTRUMENT. OBSERVE ALL
APPLICABLE SAFETY PRECAUTIONS.
=====

Refer to Figure 6.1 for the location of the various adjustments and test points. In the following sections, steps marked (NR) are not required if the quantity in question is not needed or the calibration equipment is not available. They may be bypassed without affecting subsequent steps.

6.2 Calibration Steps

Turn on the IMF-600, cover the top with a flat object and allow it to warm up for 15-20 minutes. For best results, keep it covered when not being accessed in all the following procedure.

6.2.1 Power Supply Check

Use a voltmeter to check the three power supplies at the J1PS connector. Use the rear panel COMMON terminal for the voltmeter low input. The voltages, starting from the left (looking from the front of the unit) are:

+12V, +5V, GND, -12V (within 10%)

6.2.2 DC Voltage Calibration (NR)

1. Set the unit on DCV Range 1.
2. Use a 4-1/2 digit voltmeter or a voltage standard to

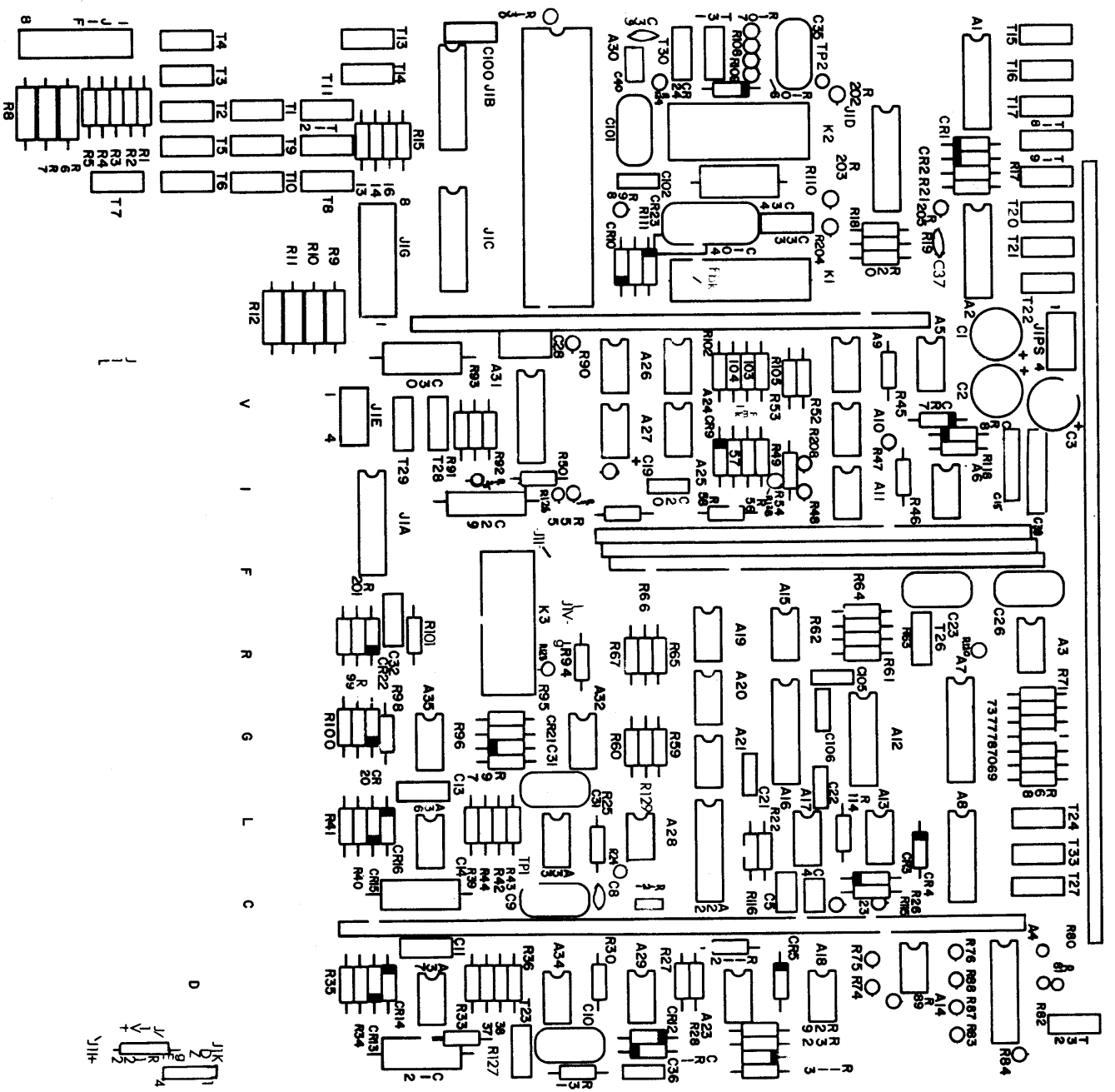

Figure 6.1 Adjustment and Test Point Locations

calibrate the 200.0 mV range with a source producing over 1900 counts. Adjust trimmer T31 to obtain a correct reading.

3. Set the unit on DCV Range 2.

4. Repeat step 2 for the 2.000 V range. Adjust trimmer T30 to obtain a correct reading.

6.2.3 AC Voltage Calibration (NR)

1. Set the unit on AC RMS V Range 1. Short the test leads together.

2. Adjust trimmer T29 for a reading of .000

3. Set the unit on Range 2.

4. Using either a 4-1/2 digit ac voltmeter (conventional or RMS) or a standard ac voltage source, apply a 100 Hz sinusoidal voltage of 1.9-2.0 V across the test leads. Adjust trimmer T28 for a correct reading.

5. Trim AC Range 3 (20.00V) high frequency response in either of the following two ways:

a) Using an RMS ac voltmeter or a standard source, apply a 19-20 volt RMS square wave. Adjust trimmer capacitor C1 on the rotary switch (the one to the left, looking from the front of the unit) for a correct reading.

or b) Using an ac voltmeter (conventional or RMS) or a standard source, apply a 10kHz 19-20 volt sinusoidal signal, and adjust trimmer capacitor C1 for a correct reading.

WARNING

=====

USE A CURRENT LIMITED SOURCE FOR THE FOLLOWING STEP AND OBSERVE ALL SAFETY PRECAUTIONS. IF THIS STEP CANNOT BE DONE SAFELY, IT SHOULD BE BYPASSED.

=====

6. Trim the AC RMS Range 4 high frequency response as in step 5, using 190-200 V, and adjusting trimmer capacitor C2 on the rotary switch (the one on the right, looking from the front of the unit).